

CTETRACCESS 200

↑ 20 m

→ 8,5 m

👤 250 kg

The ideal for rental companies.

Easy to maintain.
Easy to use.
Easy to handle.



CTE TRACCESS 200

20 m of working height, an impressive outreach of 8,4 m with 250 kg of basket capacity.



watch the video



Unrestricted working area



Absolute verticality with one command



250 kg impressive basket capacity



Different power sources available

TECHNICAL DATA

- » Articulated boom (two elements) + telescopic boom (main boom + 1 extension) + jib
- » Sigma boom moved by connecting rods
- » 320° turret rotation
- » Proportional electrohydraulic controls in basket
- » Engine start and stop controls from basket
- » All aluminium basket 1400x700x1100mm
- » 90° right + 90° left hydraulic basket rotation
- » Hydraulic basket levelling
- » Dual drive speed
- » Extendible track width
- » 12V electric system
- » 36 lt hydraulic oil tank
- » Load cell
- » N° 4 hydraulic outriggers
- » with ground pressure sensors
- » Hour meter
- » 230 V AC EC electrical socket in the basket
- » Standard boom colours
- » blue (RAL 5017) or white (RAL 9003)
- » Max gradeability 25%
- » Max drive speed 1,5 Km /h
- » 230 V 1,5 Kw auxiliary engine

ENGINES

- » Honda 15 Hp petrol engine
- » Kubota diesel engine



ALUMINUM BASKET WITH LADDER

CABLE PUSHBUTTON

EXPANDABLE TRACK

EQUIPPED WITH JIB

WORKING ENVELOPE

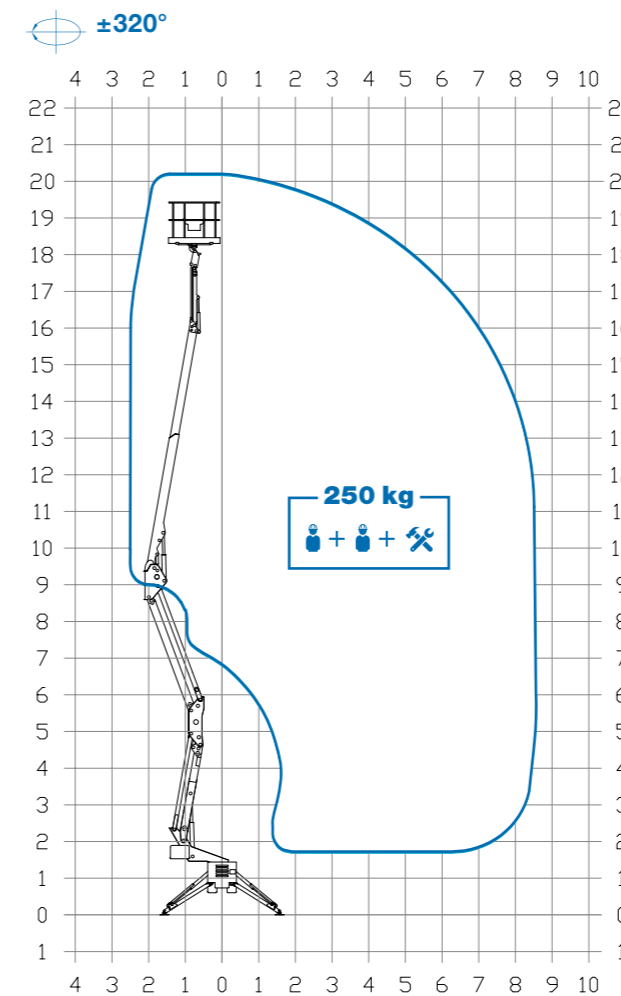

OUTRIGGER FOOTPRINT

Live loads N/m²

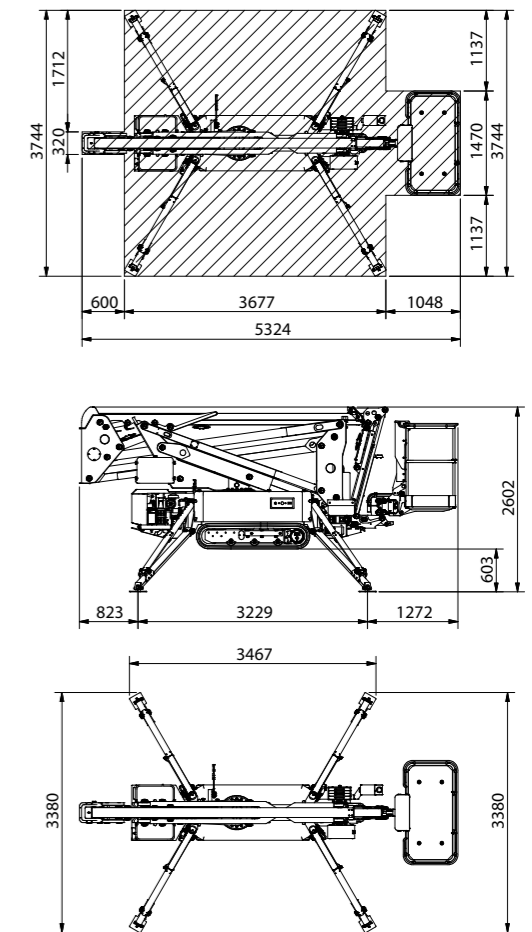

DIMENSIONS

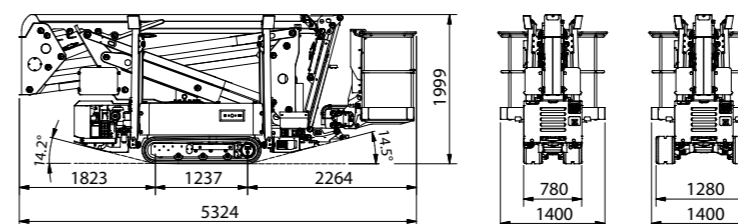

- 20* m
- 1,4 x 0,7 x 1,1 m
- 8,5* m
- 2.050 kg
- 250 kg
- 18 m

* outreach and height max values and repeatability can change within ± 3% due to manufacturing variation and working condition.



Track-mounted range from 13 m to 27 m

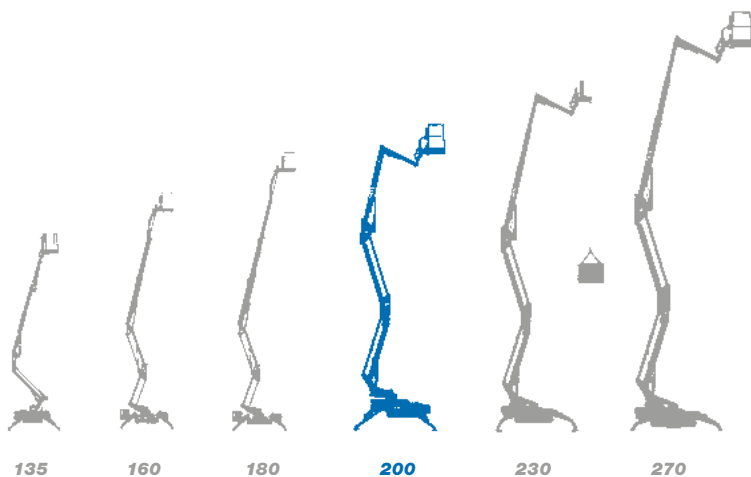

- ★ Most versatile boom configuration
- ★ Most compact machines in class
- ★ Clean top boom
- ★ Friendly to use intuitive controls
- ★ Easy maintenance
- ★ Excellent boom rigidity during operation
- ★ Versatility of engines and versions



We are CTE, one of the largest european groups in the field of lifting people and handling of material.



After sales assistance



Service spare parts



Scheduled maintenance



On-site assistance



Authorized workshops

Efficient services, innovative technical solutions, timely assistance, professional advice and training: 'Work Becomes Easy' is all this. A style, a philosophy at the heart of which are our customers, their safety, their quality of life. For this reason there is a group in CTE united by ideas, motivation and passion to simplify the work of companies active in the lifting of people and objects.



CTE s.p.a.
Via Caproni, 7
38068 Rovereto (TN)

Factory
Loc. Terramatta, 5
37010 Rivoli Veronese (VR)

Tel. +39 0464 48.50.50
info@ctelift.com
www.ctelift.com



UNI EN ISO 9001:2008 IT 61659